



Operating instructions

Series SX402

Alphanumeric displays with serial interface

GERMANY

Siebert Industrieelektronik GmbH
Siebertstrasse, D-66571 Eppelborn
Phone +49 (0)6806 980-0
Fax +49 (0)6806 980-999
www.siebert.de, info@siebert.de

AUSTRIA

Siebert Österreich GmbH
Mooslackengasse 17
A-1190 Wien
Phone +43 (0)1 890 63 86-0
Fax +43 (0)1 890 63 86-99
www.siebert-oesterreich.at
info@siebert-oesterreich.at

SWITZERLAND

Siebert AG
Bützbergstrasse 2, Postfach 91
CH-4912 Aarwangen
Phone +41 (0)62 922 18 70
Fax +41 (0)62 922 33 37
www.siebert.ch, info@siebert.ch

FRANCE

Siebert France Sarl
33 rue Poincaré, F-57203 Sarreguemines Cédex
Phone +33 (0)3 87 98 63 68
Fax +33 (0)3 87 98 63 94
www.siebert.fr, info@siebert.fr

NETHERLANDS

Siebert Nederland B.V.
Korenmaat 12b
NL-9405 TJ Assen
Phone +31 (0)592-305868
Fax +31 (0)592-301736
www.siebert-nederland.nl
info@siebert-nederland.nl

© Siebert Industrieelektronik GmbH

This operation manual has been prepared with the utmost care. However, we do not accept any liability for possible errors. We always appreciate your suggestions for improvement, corrections, comments and proposals. Please contact us: redaktion@siebert.de

Siebert[®], LRD[®] and XC-Board[®] are registered trademarks of Siebert Industrieelektronik GmbH. All other product names mentioned herein may be the trademarks or registered trademarks of their respective owners.

We reserve the right to make alternations to the technical data and delivery options without notice. – All rights reserved, including the rights of translation. No part of this document may in any form or by any means (print, photocopy, microfilm or any other process) be reproduced or by using electronic systems be processed, copied, or distributed without our written permission.

Validity

The model designation of the units is:

SX402-220/05/0G-001/0B-S0	SX402-220/05/0G-001/0B-T0
SX402-420/05/0G-001/0B-S0	SX402-420/05/0G-001/0B-T0
SX402-240/05/0G-001/0B-S0	SX402-240/05/0G-001/0B-T0
SX402-220/09/0G-001/0B-S0	SX402-220/09/0G-001/0B-T0

Table of contents

Chapter 1	Dimensions	
Chapter 2	Unit description	Principle circuit diagram Parameterization Serial Interface Status indicators
Chapter 3	Control	Text types Commands Online-Text Display static text Deleting text Line break Flashing Character set Bar graph \$ character Reset Paging Initial text
Chapter 4	Individual line selection	Application Commands
Chapter 5	Parameterization	Menu operation Menu table Serial Interface Interface parameter Programming operation Addressing Time-out

Initial text
Paging interval
Character set

Chapter 6	Notes on RS485 interface configuration	Data lines Menu settings
Chapter 7	Programming of the units	
Chapter 8	Status messages	
Chapter 9	Character table	
Chapter 10	Technical data	

Chapter 1 | Dimensions

SX402-220/05/0G-001/0B-xx (2 x 20 characters, character height 5 mm)

SX402-420/05/0G-001/0B-xx (4 x 20 characters, character height 5 mm)

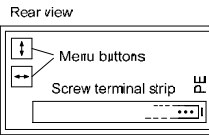
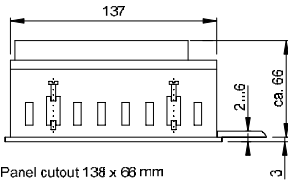
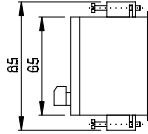
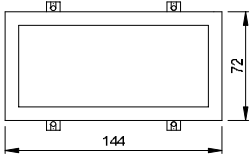

Panel cutout 138 x 68 mm

Dimensions in mm

SX402-240/05/0G-001/0B-xx (2 x 40 characters, character height 4,7 mm)

SX402-220/09/0G-001/0B-xx (2 x 20 characters, character height 9 mm)

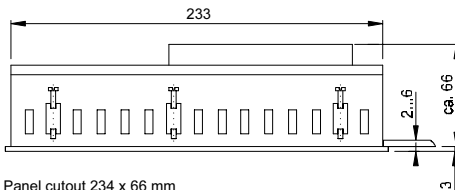
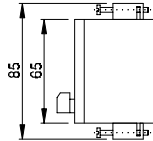
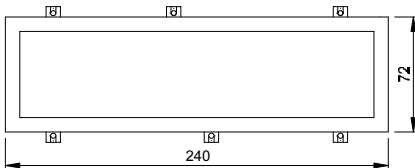

Rear view

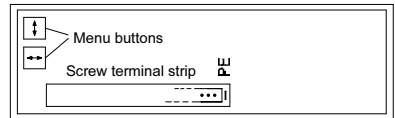

Panel cutout 234 x 66 mm

Dimensions in mm

Chapter 2 | Unit description

Principle circuit diagram

SX402-xxx/xx/0G-001/0B-S0 (interface RS485/RS232)

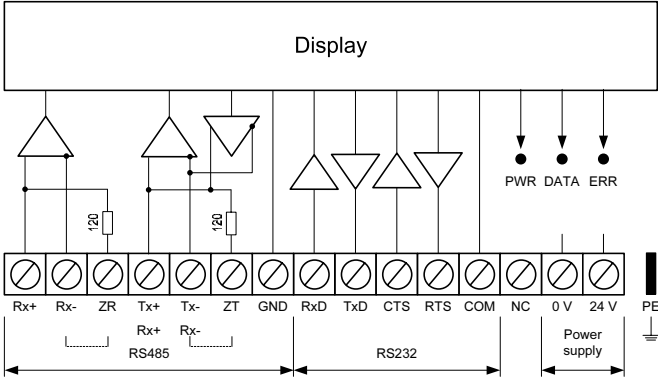

SX402-xxx/xx/0G-001/0B-T0 (interface TTY 20mA/RS232)

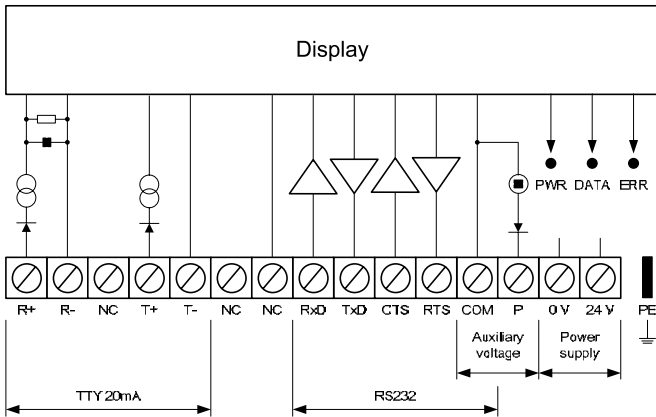

Parameterization | The parameterization of the unit is done by means of a menu in the menu display (see chapter 5).

Serial interface | The serial interface is located on a screw-type terminal. Depending on the device model, it has the following formats:

SX402-xxx/xx/0G-001/0B-S0 RS485 and RS232
SX402-xxx/xx/0G-001/0B-T0 TTY 20mA and RS232

The interface format is set in menu item 1 (see chapter 5).

Preferably, the interfaces RS485 or TTY 20 mA are to be used for activation. They are galvanically isolated from all other electric circuits and provide the best preconditions for a reliable and safe operation of the devices due to its physical characteristics.

The resistance in the clamps ZR and ZT is used to close the data line of the RS485 (see chapter 6).

The interface is determined for programming the device using a computer, for example for loading static texts in the text memory and for installing character sets by means of the PC tool 'DisplayManager' provided on data carrier (see chapter 3).

Status indicators | The status indicators (LEDs) are located on the back side of the device. They have the following function:

PWR	Operational readiness
DATA	Data are received
ERR	Communication error

Chapter 3 | Control

Text types | Dynamic and static texts can be displayed by the devices.

Dynamic texts can be changed while the unit is running. They are generated from within the process and sent to the display as data telegram.

Static texts cannot be changed while the unit is running. They are compiled using the PC tool 'DisplayManager' delivered on data carrier and loaded in the text memory via the serial interface RS232. Then, they can be opened via their text number.

Commands | The control of the devices is done using commands according to the following command table. In the description, the numbers in [] refer to the corresponding lines in the command table.

Some of the commands require a telegram ending (↵). It depends on the protocol set in menu item 5 (see chapter 5). The telegram ending of the CR/LF protocol is marked by the characters CR (0Dh), LF (0Ah) or CR/LF. The telegram ending of the protocol STX/ETX is marked by the characters ETX.

Commands for text manipulation

Online-Text	<u>cc...↵</u>	send any character (cc... = characterband with any content)	[1]
Display static text	<u>\$Tn↵</u>	Call static text (n = number, 1 to 3 digits)	[2]
Deleting text	<u>\$E↵</u>	Clearing text in the display	[3]

Commands for text formatting

Line break	<u>\$C</u>	Forced line break	[4]
Flashing	<u>\$F1</u>	Flashing of following characters on	[5]
	<u>\$F0</u>	Flashing of following characters off	[6]
Character set	<u>\$M1</u>	Standard character set	[7]
	<u>\$M2</u>	User-defined character set	[8]

Commands for text formatting (cont.)

Bar graph	\$Gnnn	Bar graph display (nnn = number of columns, always enter in three numeric digits, e. g. \$G040)	[9]
-----------	---------------	---	-----

\$ character	\$\$	Display of the '\$' character in the text	[10]
--------------	-------------	---	------

Commands for display options

Flashing	\$F1↓	Flashing of the entire display on	[11]
----------	--------------	-----------------------------------	------

	↓F0	Flashing of the entire display off	[12]
--	------------	------------------------------------	------

Reset	\$0↓	Restarting the display	[13]
-------	-------------	------------------------	------

Display online texts | To display a dynamic text, its characters (cc...) are sent to the display as a data string [1]. Any text in the display is cleared when a fixed text is called up.

Display static text | A static text is called up using the command **\$Tn↓** [2]. n is the text number; it can be from one to three digits. Any text in the display is cleared when a fixed text is called up.

Deleting text | Any text in the display is cleared with the **\$E↓** command [3]. Afterwards the following will appear on the display: >.

Line break | A line break occurs automatically if a text has more characters than can be displayed in one line. The rest of the text will then be displayed in the next line.

A line break can also be forced at a certain place in the text, for example for correct hyphenation [4] using the command **\$C**.

Flashing | Including **\$F1** in the data string causes the following characters to flash [5]. **\$F0** command in the data string deactivates the flashing of the following characters [6].

\$F1↓ command activates the flashing of the entire display [11]. **\$F0↓** command deactivates the flashing of the entire display [12].

Character set | The character set for all characters can be chosen in the text. The command **\$M1** in the data string causes all following characters to be displayed in standard character sets [7]. The command **\$M2** in the data string causes all following characters to be displayed in user defined character sets [8]. If no user defined character set is installed, all the characters are shown in the standard character set.

Bar graph | The **\$Gnnn** command activates the bar graph display [9]. **nnn** stands for the number of illuminating columns, i.e. the length of the bar graph and must always be three digits, e. g. **\$G040**.

Character \$ | The command for displaying the '\$' character is **\$\$** [10].

Reset | **\$0↵** command restarts the unit [13].

Paging | If a text contains more characters than can be shown in the display, it is automatically displayed in paging mode. The page change interval can be set between 2, 5 or 10 seconds in menu item P (see chapter 5).

Initial text | After power-on, **➤** is displayed to signalize that the unit is ready for operation. If an initial text is to appear in the display instead (e.g. 'System operational'), this text is to be saved in the text memory with text number 0, and displaying of the initial text is to be set in menu item A (see Chapter 5).

Chapter 4 | Individual line selection

Application | The activation of the devices as described in chapter 4 is optimized for applications in which individual texts are shown in the display. Longer texts are written in several lines of the display due to the automatic line break. When the text contains more characters than can be displayed, it will automatically be displayed in paging mode.

The individual line selection is optimized for applications in which several texts independent of one another should be shown in different lines and each line should be considered as an individual display. The lines can be selected individually. The control commands only refer to the activated line. The automatic line break and paging functions are not active.

Commands | The activation of the individual lines is carried out according to the following command table.

The commands beginning with **\$Lx** select an individual line. **x** is the line number (1...4).

The commands require a telegram ending (↵). It depends on the protocol set in menu item 5 (see chapter 5). The telegram ending of the CR/LF protocol is marked by the characters CR (0Dh), LF (0Ah) or CR/LF. The telegram ending of the protocol STX/ETX is marked by the characters ETX.

Commands

Online-Text	\$Lxcc...↵	Send any character to line x (cc... = characterband with any content)	[14]
Display static text	\$Lx\$Tn↵	Load static text in the line x (n = text number, 1 to 3 digits)	[15]
Deleting text	\$Lx\$E↵	Delete the text in the line x	[16]
Flashing	\$Lx\$F1↵	Flashing of the whole line x on	[17]
	\$Lx\$F0↵	Flashing of the whole line x off	[18]

Menu display | The parameterization of the devices is carried out in a menu of the display. To reach the menu, press both menu buttons simultaneously (approx. 1 sec.) until an audible signal is heard and menu item 01 appears in the display. Now, you can navigate in the menu as follows:

Next menu item:	Shortly press key [↕]
Page menu items forward:	Press key [↕] long
Previous menu item:	Double click on key [↕]
Page menu items backward:	Double click on [↕] and keep it pressed
Next setting	Shortly press key [↔]
Page settings forward:	Press key [↔] long
Previous setting	Double click on key [↔]
Page setting backward:	Double click on [↔] and keep it pressed

The menu ends in menu item U with the button [↕]. The settings made are either saved (set), not saved (escape) or the factory settings, except for menu item 1, are reset, depending on the setting selected in menu item U.

Cancelling the menu without saving the settings made is possible by pressing both menu buttons longer (approx. 1 sec.) or will occur automatically if 60 seconds pass without a menu button being pressed.

Once the menu is closed, the unit behaves in the same manner as when the operating voltage was applied.

Control of the displays is not possible in menu mode.

Menu table | The menu items are displayed in the following menu table. The factory settings are marked with an *. Individual menu items or settings can be suppressed in another menu item, depending on the unit version or setting.

Menu item	Settings	Display
1 Serial Interface	RS232	1 232
	RS485	1 485
	RS485 (4-wire bus)	1 485.4
	RS485 (2-wire bus)	1 485.2
	TTY 20mA	1 TTY
	RS232 Programming operation	1 Prog
2 Data format	7 bit with even or odd parity	2 7Bit
	8 bit with or without parity*	2 8Bit
3 Parity	No parity*	3 None
	odd parity	3 Odd
	even parity	3 Even
4 Baud rate	1200	4 1200
	2400	4 2400
	4800	4 4800
	9600*	4 9600
	19200	4 19.2
	38400	4 38.4
5 protocol	CR/LF*	5 CrLf
	STX/ETX	5 StEt
6 Protocol reply	No protocol reply*	6 None
	ACK/NAK	6 AcNa
8 Address length	No Addressing*	8 0
	1 digit	8 1
	2 digits	8 2
9 Address	Address 0	9 00
	Address 1	9 01
	↓	↓
	Address 99	9 99

Menu item	Settings	Display
A Initial text	Not displaying initial text*	A >
	Displaying initial text	A Txt0
F Character set	Standard character set*	F Std
	User-defined character set	F User
P Paging interval	2 seconds *	P 2
	5 seconds *	P 5
	10 seconds *	P 10
T Time-out	No time-out *	T 0
	Time-out after 2 s	T 2
	Time-out after 4 s	T 4
	Time-out after 8 s	T 8
	Time-out after 16 s	T 16
	Time-out after 32 s	T 32
	Time-out after 64 s	T 64
	Time-out after 128 s	T 128
U Saving	Saving parameters* (Set)	U Set
	Not saving parameters (Escape)	U Esc
	Resetting to the default settings (Default)	U Def

Serial Interface | Select in menu item 1 between the interface formats which are available in the unit.

SX402-xxx/xx/0G-001/0B-S0 RS485 or RS232
 SX402-xxx/xx/0G-001/0B-T0 TTY 20mA or RS232

Several settings are possible with the interface format RS485. Which settings are to be selected is described in chapter 6.

In the interface format RS232, the RTS/CTS handshake is always active.

Interface parameter | Data format, parity, baud rate, protocol and protocol reply are set in menu items 2 to 6.

Programming operation | If the interface RS232 is connected to a PC for programming the device, for example, for loading static texts or for installing character sets, in menu item 1, the setting **Prog** has to be selected.

Then, the parameter of the interface RS232 is set firmly as follows: 9600 bauds, 8 data bits, no parity, 1 stop bit, RTS/CTS handshake, CR/LF protocol, no addressing

In the programming mode, the display will temporarily be dark.

After finishing the programming operation, the interface parameters selected in the menu items 2 to 6 are automatically reset.

Addressing | If no addressing is desired, select the setting 0 in menu item 8.

If the devices are to be selectively addressable, they receive an individual address. In menu item 8, it is defined if the address has one or two digits.

In menu item 9, the address is set (1...99). The address 0 is reserved as broadcast address, with which all devices are addressed. If the device receives the address 0, it does not send back a telegram reply.

If the address 0 is set in menu item 9, the device is addressed with any address but it does not send back a telegram reply.

Time-out | In menu item T, it is possible to set whether a time-out occurs, and if so, after what time. Time-out means that the display is cleared if it has not received a data telegram after a defined time period. The following symbol > appears then on the display >.

Initial text | After power-on, > is displayed to signalize that the unit is ready for operation. If an initial text is to appear in the display instead (e.g. 'System operational'), this text is to be saved in the text memory with text number 0, and displaying of the initial text is to be set in menu item A see Chapter .

Paging-Interval | If the text contains more characters than can be shown in the display, it is automatically displayed in paging mode. The page change interval can be set between 2, 5 or 10 seconds in menu item P.

Character set | In menu item F, you can set the default character set used to display the texts.

The standard character set is permanently installed in the devices (setting **Std**). The setting **User** allows you to activate the user defined character set. If no user defined character set is installed, all the characters are shown in the standard character set.

The PC tool „DisplayManager“ is included in the delivery of the displays. The tool is also used to install character sets, to save character sets to data media and to read back installed character sets.

Chapter 6 | Notes on RS485 interface configuration

Data lines | To achieve the highest possible interference immunity, the data lines of the RS485 have to be terminated on both ends. The resistance necessary for this is available in the display and these can be connected to the screw-type terminal with a wire link (see chapter 2, simplified diagram, clamps ZR, ZT).

The polarization of the data lines must be ensured by means of the master.

For the data lines, you always have to ensure that:

- Shielded twisted-pair cables of sufficiently large cross-section are used.
- The shielding is connected on both line ends.
- For the signal ground (GND) use a wire pair short-circuited on both ends in the data cable. The shielding may not be used as the signal ground.
- A twisted core pair is used each for Tx+ and Tx- and for Rx+ and Rx-. Non-observance of this instruction causes the protective function of the twisted-pair cable to be lost.
- Improperly terminated data lines cause faults during data transfer.

Menu settings | The settings 485, 485.4 and 485.2 are possible interface formats for RS485 in menu point 1 (see chapter 5). The selected setting depends on whether the protocol reply is to be sent by the unit:

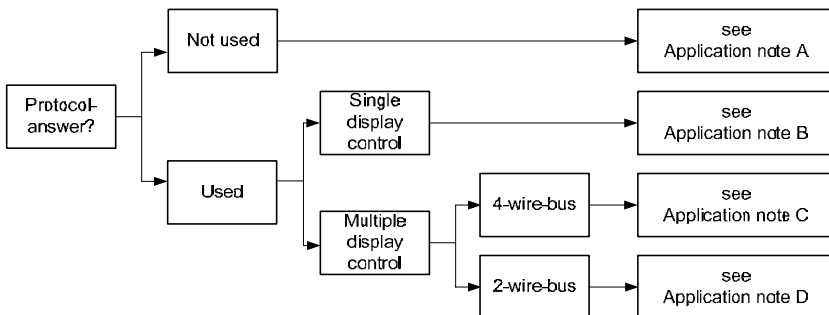

If the unit should not send a protocol reply (normal case), application example A applies for activating one or more units.

If a protocol reply is expected, a differentiation has to be made whether one single unit or more units are to be activated. If one single unit is activated, application example B is valid.

If several units are to be activated, a bus wiring is necessary. You have to differentiate, if a 4-wire bus (full-duplex) or a 2-wire bus (half-duplex) is used. Application example C applies for 4-wire bus and application example D applies for 2-wire bus.

Application example A Setting in menu item 1: RS485
Setting in menu item 6: No protocol reply

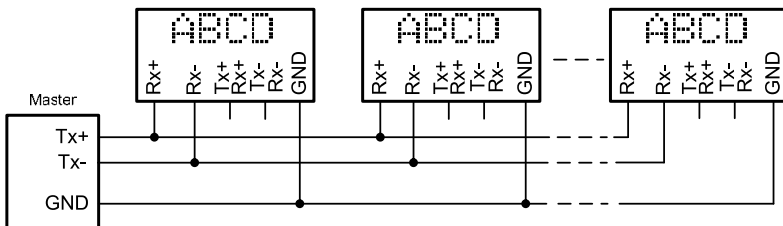

Application example B Setting in menu item 1: RS485
 Setting in menu item 6: ACK/NAK (recommended)

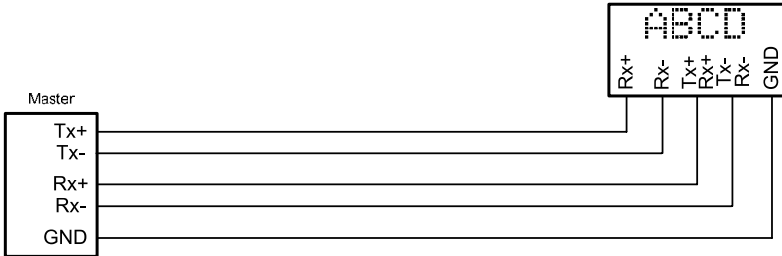

Application example C Setting in menu item 1: RS485.4
 Setting in menu item 6: ACK/NAK (recommended)

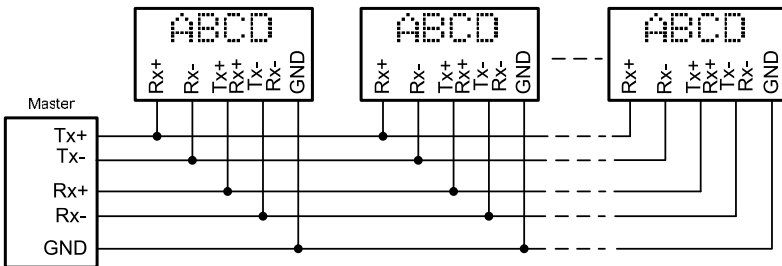

Application example D Setting in menu item 1: RS485.2
 Setting in menu item 6: ACK/NAK (recommended)

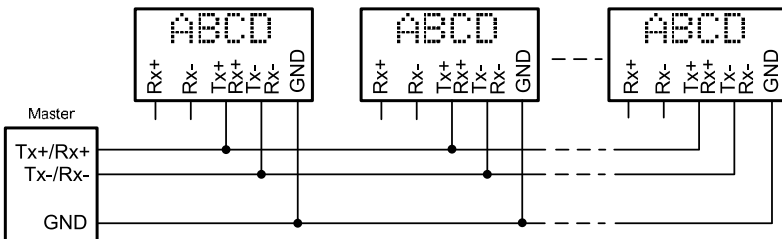

Chapter 7 | Programming of the units

A data carrier with the PC tool „DisplayManager“ is included in the delivery of the devices. It serves for creating texts and user defined character sets. For details please refer to the menu item „Help“ or to the operating manual of the PC tool.

In order to use the PC tool, the display must be connected to a PC in the following way. The handshake cables RTS and CTS should also be connected.

PC (RS232) 9 pin D Sub socket	SX402 (RS232) screw-type terminal
(2) RxD _____	TxD
(3) TxD _____	RxD
(5) COM _____	COM
(7) RTS _____	CTS
(8) CTS _____	RTS

In menu item 1 setting **PRO3** is to be selected.

In the programming mode, the display will be temporarily dark.

Chapter 8 | Status messages

Serious faults due to improper operation or faulty operating conditions are indicated in the display. The following messages are possible:

Fault message	Cause	Elimination
NO_TEXT	The text called up is not saved in the fixed text memory.	The text is to be loaded into the fixed text memory.
SYNTAX_ERROR	A faulty command was sent to the display.	The command must be corrected (see command table in chapter 7).
Time-out	An error occurred when loading static texts or user defined character sets.	The connection and the interface parameters of the PC tool must be corrected.
OVER_FLOW	Too many characters have been sent to the display or the interface parameters are incorrect.	The data telegram has to be corrected or the interface parameters of the communication partners must be adapted.
USE_PROG!	One tried to use the PC tools without the setting Prog in the menu.	In menu item 1 setting Prog is to be selected.

Chapter 9 | Character table

	0	1	2	3	4	5	6	7	8	9	A	B	C	D	E	F
2		!	"	#	\$	%	&	'	()	*	+	,	-	.	/
3	0	1	2	3	4	5	6	7	8	9	:	;	<	=	>	?
4	@	A	B	C	D	E	F	G	H	I	J	K	L	M	N	O
5	P	Q	R	S	T	U	V	W	X	Y	Z	[\]	^	_
6	'	A	B	C	D	E	F	G	H	I	J	K	L	M	N	O
7	P	Q	R	S	T	U	V	W	X	Y	Z	{		}	~	Δ
8	€	ç	é	ä	ë	ä	ä	ç	è	é	è	i	î	ï	ä	ä
9	é	*	*	ô	ö	ö	ö	ü	ö	ü	ø	£	ø	×	ƒ	
A	ä	í	ó	ú	ñ	ñ	º	º	■	¬	¬	¼	¼	½	¾	
B	∴	⊗	■	∣	∣	■	■	■	■	■	■	¾	≡	¢	¥	€
C	À	É	Ê	Ë	Ì	Í	Î	Ï	Ï	Ï	Ï	Ï	Ï	Ï	Ï	Ï
D	P	C	T	Y	Φ	X	Ц	Ч	Ш	Щ	Ъ	Ы	Ь	Э	Ю	Я
E	α	β	γ	π	Σ	σ	μ	τ	ι	ε	Ω	δ	∞	∅	e	n
F	≡	±	¿	≤	■	■	÷	∞	°	·	·	√	*	2	■	ƒ

The characters 00_h to 1F_h are replaced by blanks.

Chapter 10 | Technical data

Display range	SX402-220/xx/0G-001/0B-xx	2 x 20 characters
	SX402-420/xx/0G-001/0B-xx	4 x 20 characters
	SX402-240/xx/0G-001/0B-xx	2 x 40 characters
Character height	SX402-220/05/0G-001/0B-xx	approx. 5 mm
	SX402-420/05/0G-001/0B-xx	approx. 5 mm
	SX402-240/05/0G-001/0B-xx	approx. 4,7 mm
	SX402-220/09/0G-001/0B-xx	approx. 9 mm
Display color	green	
Protection type	IP65 (front)	
Operating voltage	24 V DC \pm 15 %, galvanically isolated, protected against reversed polarity	
Power consumption	approx. 7 VA	
Connection	Pluggable screw-type terminal strip clamping range 0,08...2,5 mm ²	
Operating temperature	0...50 °C	
Storage temperature	-20...70 °C	
Relative humidity max.	95 % (non-condensing)	
Weight	SX402-220/05/0G-001/0B-xx	approx. 450 g
	SX402-420/05/0G-001/0B-xx	approx. 450 g
	SX402-240/05/0G-001/0B-xx	approx. 600 g
	SX402-220/09/0G-001/0B-xx	approx. 600 g
Fixed text memory	Capacity	16 KBytes
	Number of texts	max. 128 (static texts)
Text length	The text length of static texts is not limited but must not exceed the capacity of the text memory. Dynamic texts can have a length of 200 characters at the most; formatting is included in the 180 characters.	